

Unit - tables technical specification



.mdd

.mdd has a leading position among manufacturers of office furniture with many awards that prove quality and continuously increase demand for it's products.

The realities of today`s market require constant quality improvement at all levels of modern organization. This applies in particular to customer service, marketing, quality of products and also to quality of processes within the company. Partnership relations among employees and with business partners form a base of economic growth and success of the company.

Constant investments in innovative machinery park, optimization of management systems and an expansion of production halls allow to minimize the lead times for the product of the highest quality.

More than twenty years of experience in office furniture industry come with reference from a long list of companies and institutions to show their appreciation for an efficient and comprehensive service.

.mdd is highly aware of the environment.

Being located in the forest region with lake by its side, .mdd takes the nature seriously and invests constantly in a modern and energy-efficient solutions to preserve the local life. Company puts emphasis on waste segregation and recycling. .mdd has been awarded for the exceptional care and involvement in waste disposal. All materials used are environmentally friendly and enjoy a high 95 % rate of being recycled.



General informations:

Warranty:

.mdd products - **5 years**.
Electrical components and fabric - **2 years**.

Assembly:

the product comes pre-assembled

Packing:

cardboard, foam wrap

Certificate - MFC:



Material composition *:

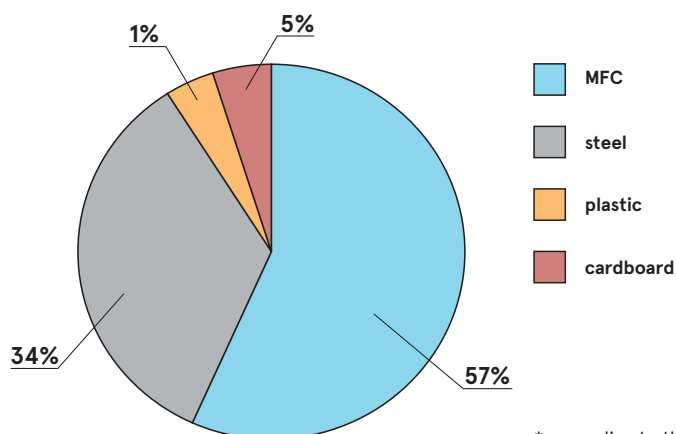

Recyclability **

Recyclable: 92 - Downcyclable: 8%

Recycled content

81,5%

Co2 carbon footprint

48,5 kg

* according to the EPD document

** average values for a representative of the group; values may vary for other products

Technical specification

- 1. **Worktop** - 30 mm thick, veneer/HPL
- 2. **Frame** - metal, powder coated, frame made of tube Ø 35 mm
- 3. **Frame** - aluminum, profile 80x30 mm
- 4. **Polypropylene feet** - colour: black

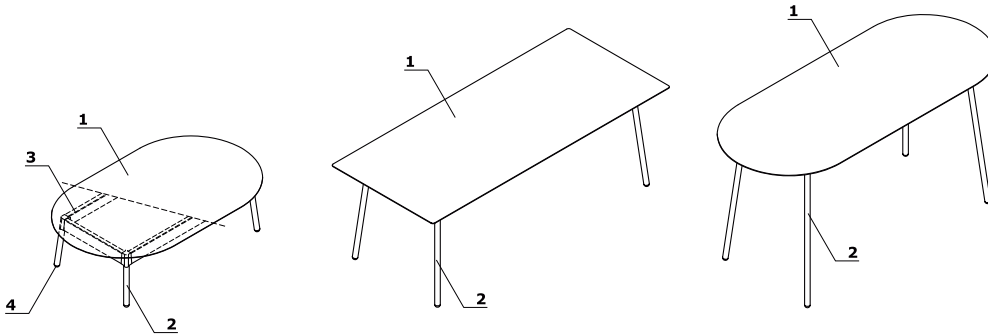

Unit - tables	Date of preparation 06.02.2023	The data contained in this document is valid in the day of its preparation. Change of the product, as long as it does not affect the basic features of it, does not require consistent updates of the document.	page 3/5 technical description
----------------------	-----------------------------------	---	--

Meeting tables *

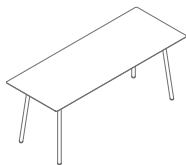

UN18
1800 / 700 / 740
36.7 kg

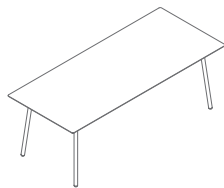

UN21
2100 / 900 / 740
47 kg

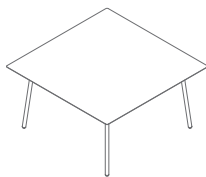

UN14
1400 / 1400 / 740
48.5 kg

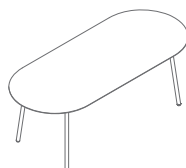

UN219
2100 / 900 / 740
43.3 kg



UN90
900 / 900 / 740
24 kg



UN120
1200 / 1200 / 740
33.2 kg

* dimensions expressed in millimeters: width x depth x height

Unit - tables	Date of preparation 06.02.2023	The data contained in this document is valid in the day of its preparation. Change of the product, as long as it does not affect the basic features of it, does not require consistent updates of the document.	page 4/5
			products

Top - veneer



181 Natural oak



182 Black oak



191 Copper oak

Top - HPL



183 Fenix - black
matte

Leg - metal



M016 Pearl white
semi-matt RAL1013



M115 Black
semi-matt RAL9005

* ATTENTION - Top edging always matching the colour of the framework.